

Moderate shock, angle 45°

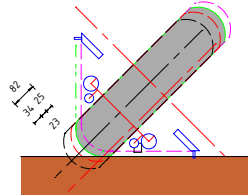

Dynamic sag, angle 45°

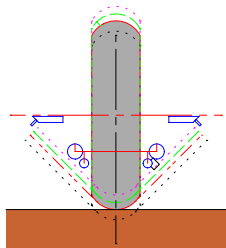

Static sag with rider

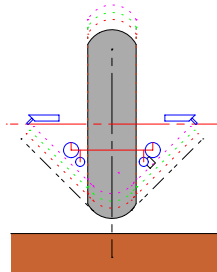

Main stand

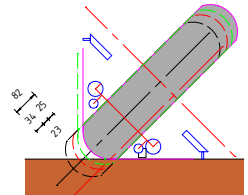
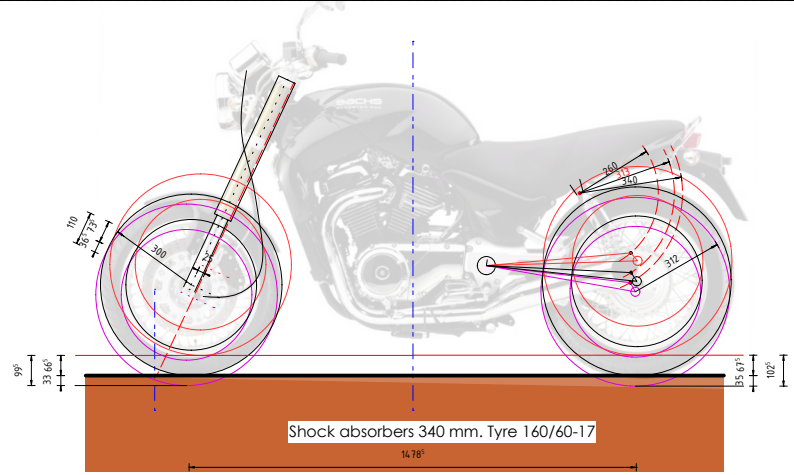

Moderate shock, angle 45°

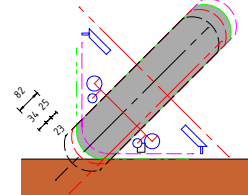

Dynamic sag, angle 45°

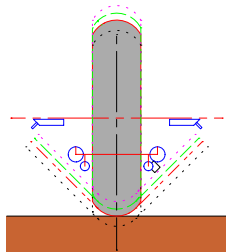

Static sag with rider

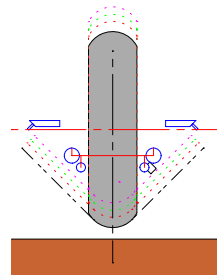

Main stand

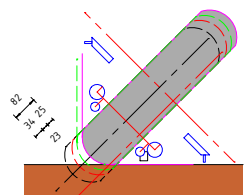
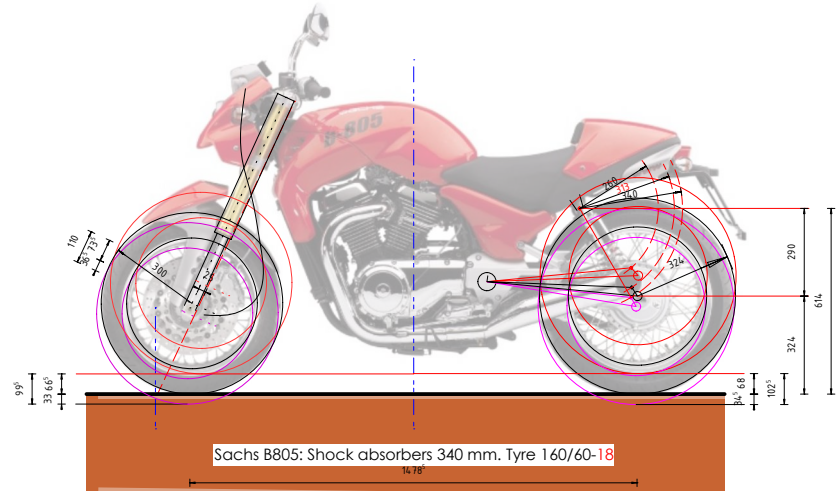

Moderate shock, angle 45°

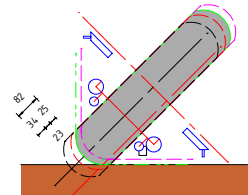

Dynamic sag, angle 45°

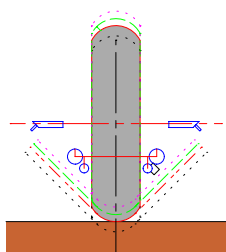

Static sag with rider

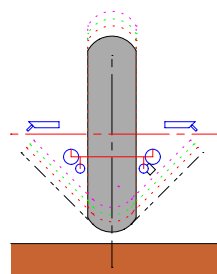

Main stand

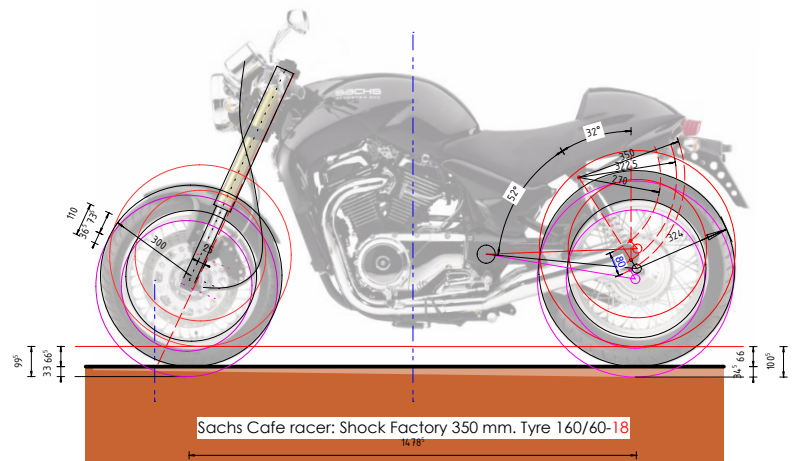

01 E
11/02/2021
Ech = 1:25

Sachs Cafe racer F805
Suspension modification

